

# HSF

**NOTES:**

Rated Current:1.5AMP.(20°C,1\*2P-1\*15P)  
 1.0AMP.(20°C,1\*16P-1\*50P)  
 Contact Resistance:20mΩ Max.  
 Withstand Voltage:500V AC/DC  
 Insulation Resistance:1000MΩ Min.  
 Operation Temperature:-40°C to +125°C(Gold Plating)

Contact Material:Copper Alloy  
 Contact Plating: Au Over 30u" Min Ni  
 Insulator Material:PA9T+G.F UL94V-0 BK

## Ordering Information

**2321-1 XX S XX C U N T 1**

Plastic Row  
 No. of Pins  
 Per Row:02~50  
 Welding Type  
 S=S/T  
 Contact Plating  
 G0=Gold Flash  
 G3=10u"Au, BG3=8u"PdNi+2u"Au  
 G4=15u"Au, BG4=13u"PdNi+2u"Au  
 G5=30u"Au, BG5=28u"PdNi+2u"Au  
 Series No.  
 Packing:  
 T=Tube  
 Logo  
 N=W/O Logo  
 Contact Type  
 U=U Type  
 Insulator Material  
 C=PA9T

Recommended P.C.B Layout(Top Side)  
 (PCB BOARD TOLERANCE±0.05)  
 (PCB Thickness:T=1.60m)

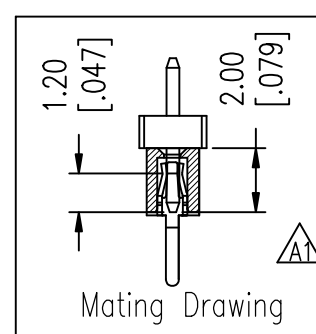
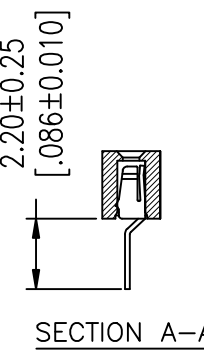
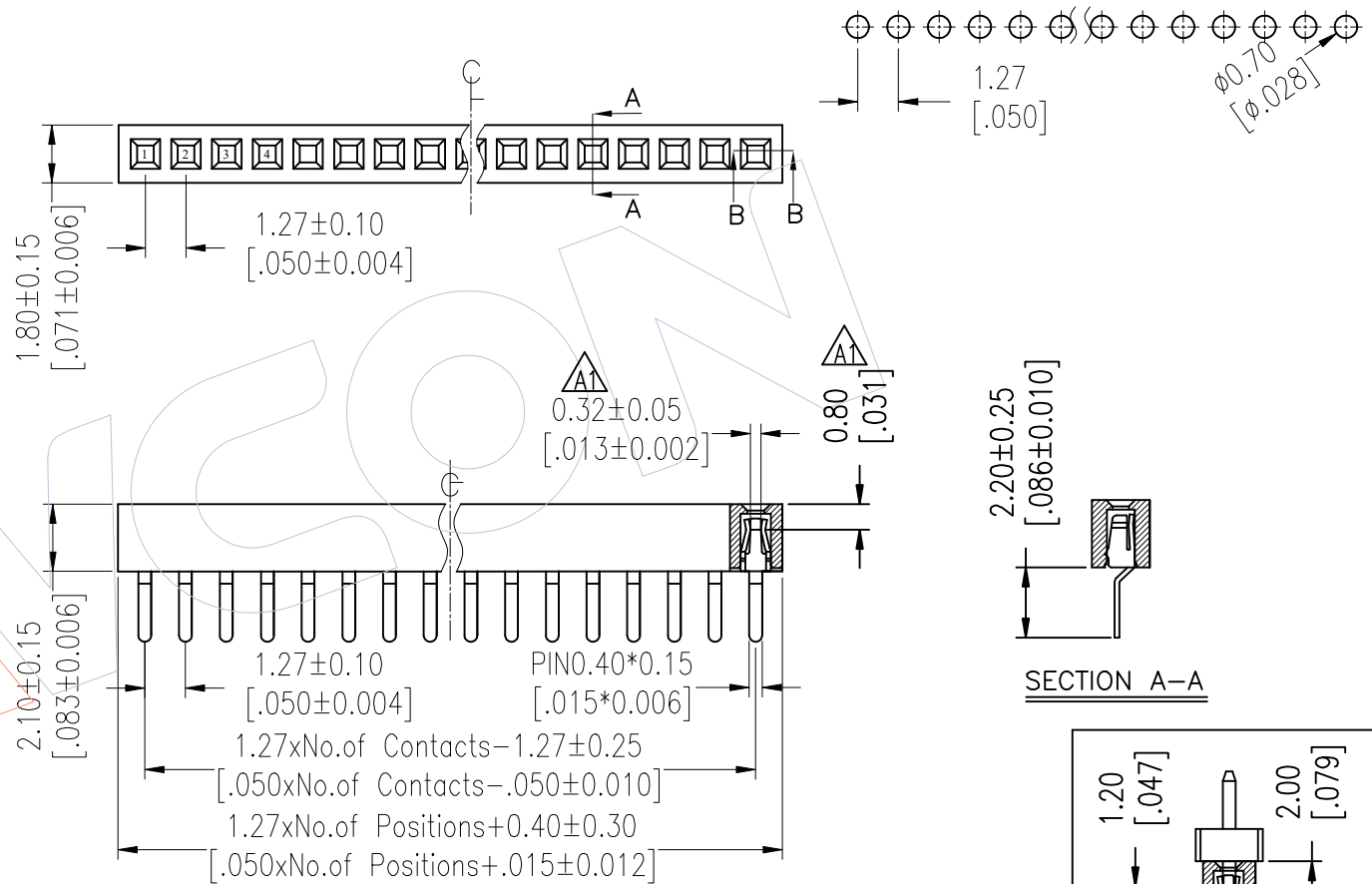

Item	Pitch	Mating	DIM.B
Standard	1.27	1310/1315/1320	2.00
Alternate			

REV	DATE	MODIFICATION DESCRIPTION	CHANGE	OPERATION	DRAW BAO	DATE	SCALE	FIT	PART NO.
A1	2025/12/15	Standardization Drawing	BAO	x.X ±0.40	CHECK TANG	2025/12/15	UNIT mm	A4	2321-1XXSXXCUNT1
AO	2012/07/06	NEW	-----	x.XX ±0.25	APPROVE Steven Zhao	2025/12/15	SIZE A4	1/2	TITLE: FH1.27mm SINGLE ROW 180° DIP H=2.10
				x.XXX ±0.15			SHEET		Customer NO.
				Angle ± 3'			PROJ.		
				DIM TOL					

**WCON**  
 Http: www.wcon.com  
 WCON-Dongguan Tel: +86 769 85358920 Fax: +86 769 85358915 E-mail: sales@wcon.com  
 WCON-Kunshan Tel: +86 512 57468408 Fax: +86 512 57468468 E-mail: salesks@wcon.com

**HSF**

**Packing:**



**Packaging Quantity Refers To The Following Table**

**Tube:**

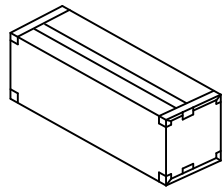
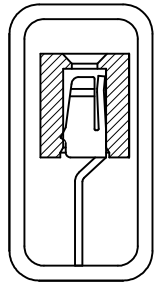

Inner Box

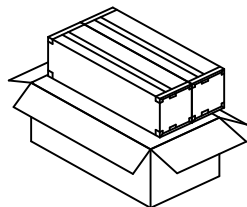

Box

PINS	Q' ty/Tube	Q' ty/Inner Box	Q' ty/Box
2	2,500/Tray	/	120,000
3	138	82,800	165,600
4	105	63,000	126,000
5	86	51,600	103,200
6	72	43,200	86,400
7	62	37,200	74,400
8	54	32,400	64,800
9	49	29,400	58,800
10	44	26,400	52,800
11	40	24,000	48,000
12	37	22,200	44,400
13	34	20,400	40,800
14	32	19,200	38,400
15	29	17,400	34,800
16	28	16,800	33,600
17	26	15,600	31,200
18	25	15,000	30,000
19	23	13,800	27,600
20	22	13,200	26,400
21	21	12,600	25,200
22	20	12,000	24,000
23	19	11,400	22,800
24	18	10,800	21,600
25	18	10,800	21,600
26	17	10,200	20,400

PINS	Q' ty/Tube	Q' ty/Inner Box	Q' ty/Box
27	16	9,600	19,200
28	16	9,600	19,200
29	15	9,000	18,000
30	15	9,000	18,000
31	14	8,400	16,800
32	14	8,400	16,800
33	13	7,800	15,600
34	13	7,800	15,600
35	13	7,800	15,600
36	12	7,200	14,400
37	12	7,200	14,400
38	12	7,200	14,400
39	11	6,600	13,200
40	11	6,600	13,200
41	10	6,000	12,000
42	10	6,000	12,000
43	10	6,000	12,000
44	10	6,000	12,000
45	10	6,000	12,000
46	9	5,400	10,800
47	9	5,400	10,800
48	9	5,400	10,800
49	9	5,400	10,800
50	9	5,400	10,800

		OPERATION		DRAW		DATE		SCALE		FIT		2321-1XXSXXCUNT1	
		x.X	±0.40	BAO		2025/12/15		UNIT	mm		TITLE:		
A1	2025/12/15	Standardization Drawing		BAO	CHECK	DATE		SIZE	A4		FH1. 27mm SINGLE ROW 180° DIP		
AO	2012/07/06	NEW		-----	TANG	2025/12/15		SHEET	2/2		H=2. 10		
REV	DATE	MODIFICATION DESCRIPTION		CHANGE	APPROVE	DATE		PROJ.	Customer NO.		Customer NO.		
					Steven Zhao	2025/12/15					<p><b>WCON</b></p> <p>Http: www.wcon.com</p> <p>WCON-Dongguan Tel: +86 769 85358920 Fax: +86 769 85358915 E-mail: sales@wcon.com</p> <p>WCON-Kunshan Tel: +86 512 57468408 Fax: +86 512 57468468 E-mail: salesks@wcon.com</p>		