

HSF

NOTES:

Rated Current: 1.5AMP.(20°C, 1*2P-1*15P)
 1.0AMP.(20°C, 1*16P-1*50P)
 Contact Resistance: 20mΩ Max.
 Withstand Voltage: 500V AC/DC
 Insulation Resistance: 1000MΩ Min.
 Operation Temperature: -40°C to +125°C(Gold Plating)

Contact Material: Copper Alloy
 Contact Plating: Au Over 30u" Min Ni
 Insulator Material: PA9T+G.F UL94V-0 BK ΔA

Ordering Information

2321-1 XX M XX C U N X X ΔA

Plastic Row
 No. of Pins Per Row: 02-50
 Welding Type M=SMT
 Contact Plating G0=Gold Flash G3=10u"Au, BG3=8u" PdNi+2u"Au G4=15u"Au, BG4=13u" PdNi+2u"Au G5=30u"Au, BG5=28u" PdNi+2u"Au
 Logo N=W/O Logo
 Contact Type U=U Type
 Insulator Material C=PA9T
 Series No. 1=TYPE 1 2=TYPE 2
 Packing: T=Tube R=Tape&Reel+CAP P=Tube+CAP

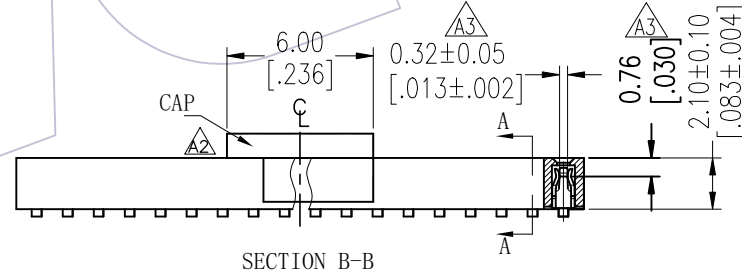
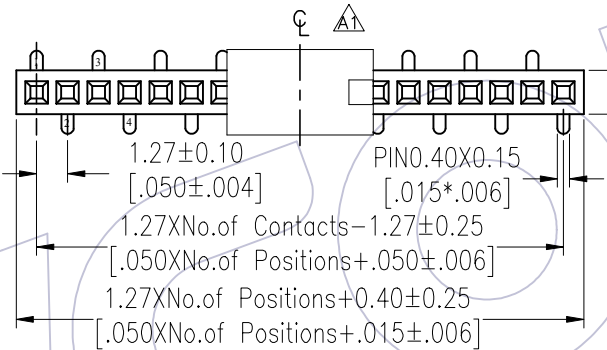
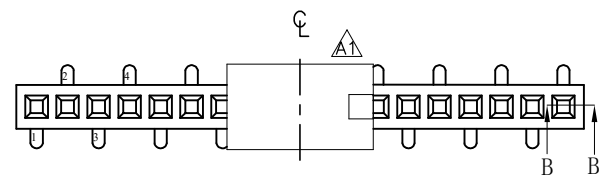

Recommended P.C.B Layout(Top Side)
 (PCB BOARD TOLERANCE±0.05)
 (PCB Thickness: T=1.60m)

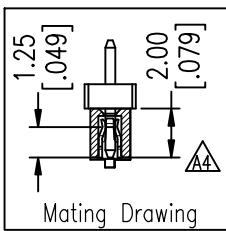
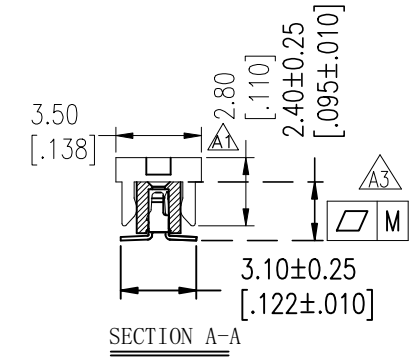
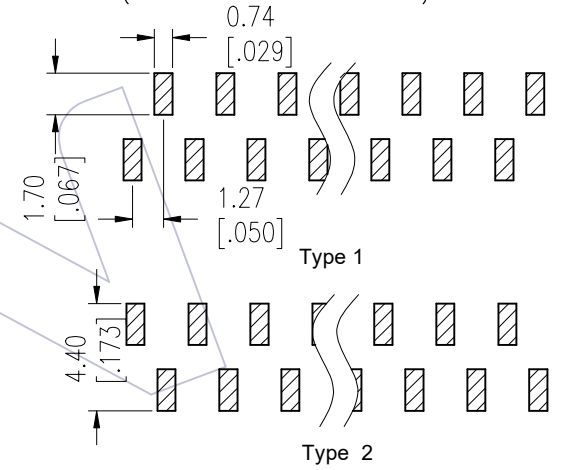

Item	Pitch	Mating	DIM.B
Standard	1.27	1310/1315/1320	2.00
Alternate			

TYPE	PART NO.			
	TYPE 1	2-15P	16-30P	31-50P
TYPE 2	M	0.10	0.15	0.18

REV	DATE	MODIFICATION DESCRIPTION	CHANGE	OPERATION	DRAW	DATE	SCALE	FIT	PART NO.
A4	2025/12/12	Standardization Drawing	BAO	OPERATION	BAO	2025/12/12	UNIT	mm	SEE TABLE
A3	2023/02/03	ADD Flatness	XSR	x.x ±0.40	CHECK	2025/12/12	SIZE	A4	TITLE: 1.27mm SINGLE FEMALE HEADER SMT H=2.10
A2	2017/04/14	MODIFY CAP	XSR	x.xx ±0.25	TANG	2025/12/12	SHEET	1/3	Customer NO.
A0	2012/07/05	NEW	-----	x.xxx ±0.15	APPROVE	2025/12/12	PROJ.		
				Angle ± 3'	Steven Zhao				

WCON
 Http: www.wcon.com
 WCON-Dongguan Tel: +86 769 85358920 Fax: +86 769 85358915 E-mail: sales@wcon.com
 WCON-Kunshan Tel: +86 512 57468408 Fax: +86 512 57468468 E-mail: salesks@wcon.com

HSF

Packing:



Tube:

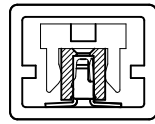

W/T CAP

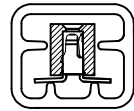

W/O CAP

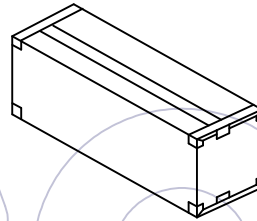

Inner Box

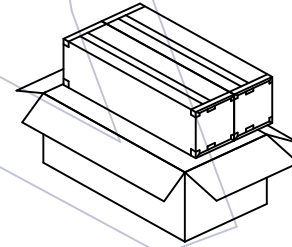
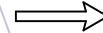

Box

Reel:

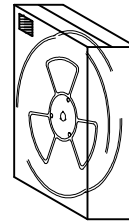
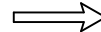
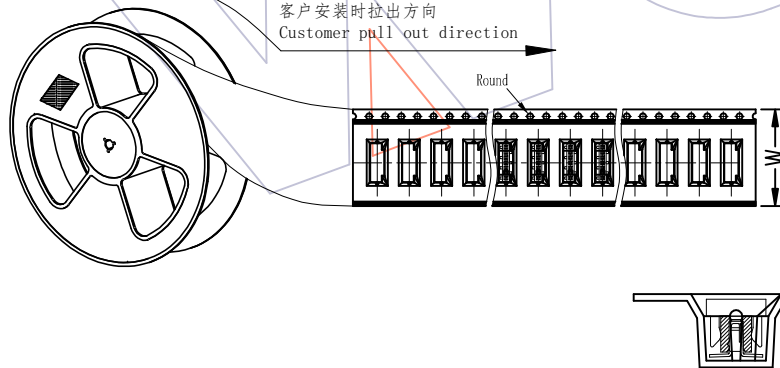

Inner Box

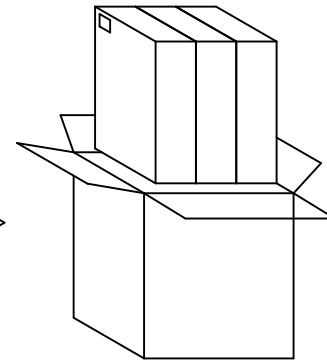
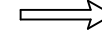

Box (Put in 3 Inner Box)

A4	2025/12/12	Standardization Drawing	BAO	OPERATION	DRAW	DATE	SCALE	FIT	PART NO.
A3	2023/02/03	ADD Flatness	XSR	x.x ±0.40	BAO	2025/12/12	UNIT	mm	SEE TABLE
A2	2017/04/14	MODIFY CAP	XSR	x.xx ±0.25	CHECK	DATE	SIZE	A4	TITLE:
A0	2012/07/05	NEW	-----	x.xxx ±0.15	TANG	2025/12/12	SHEET	2/3	1.27mm SINGLE FEMALE HEADER SMT H=2.10
REV	DATE	MODIFICATION DESCRIPTION	CHANGE	Angle ± 3'	APPROVE	DATE	PROJ.	Customer NO.	
				DIM TOL	Steven Zhao	2025/12/12			

WCON

Http: www.wcon.com

WCON-Dongguan
Tel: +86 769 85358920
Fax: +86 769 85358915
E-mail: sales@wcon.com

WCON-Kunshan
Tel: +86 512 57468408
Fax: +86 512 57468468
E-mail: salesks@wcon.com

HSF

Packaging Quantity Refers To The Following Table

PINS	Q' ty/Tube	Q' ty/Inner Box	Q' ty/Box
5	86	43,000	86,000
6	72	36,000	72,000
7	62	31,000	62,000
8	54	27,000	54,000
9	49	24,500	49,000
10	44	22,000	44,000
11	40	20,000	40,000
12	37	18,500	37,000
13	34	17,000	34,000
14	31	15,500	31,000
15	29	14,500	29,000
16	28	14,000	28,000
17	26	13,000	26,000
18	24	12,000	24,000
19	23	11,500	23,000
20	22	11,000	22,000
21	21	10,500	21,000
22	20	10,000	20,000
23	19	9,500	19,000
24	18	9,000	18,000
25	18	9,000	18,000
26	17	8,500	17,000
27	16	8,000	16,000

PINS	Q' ty/Tube	Q' ty/Inner Box	Q' ty/Box
28	16	8,000	16,000
29	15	7,500	15,000
30	15	7,500	15,000
31	14	7,000	14,000
32	14	7,000	14,000
33	13	6,500	13,000
34	13	6,500	13,000
35	12	6,000	12,000
36	12	6,000	12,000
37	12	6,000	12,000
38	11	5,500	11,000
39	11	5,500	11,000
40	11	5,500	11,000
41	10	5,000	10,000
42	10	5,000	10,000
43	10	5,000	10,000
44	10	5,000	10,000
45	10	5,000	10,000
46	9	4,500	9,000
47	9	4,500	9,000
48	9	4,500	9,000
49	9	4,500	9,000
50	9	4,500	9,000

PINS	W	Q' ty/Reel	Q' ty/Inner Box	Q' ty/Box
2	16	2,000	8,000	24,000
3	16	2,000	8,000	24,000
4	16	2,000	8,000	24,000
5	16	2,000	8,000	24,000
6	24	2,000	6,000	18,000
7	24	2,000	6,000	18,000
8	24	2,000	6,000	18,000
9	24	2,000	6,000	18,000
10	24	2,000	6,000	18,000
11	24	2,000	6,000	18,000
12	24	2,000	6,000	18,000
13	32	2,000	4,000	12,000
14	32	2,000	4,000	12,000
15	32	2,000	4,000	12,000
16	32	2,000	4,000	12,000
17	44	2,000	4,000	12,000
18	44	2,000	4,000	12,000
19	44	2,000	4,000	12,000
20	44	2,000	4,000	12,000
21	44	2,000	4,000	12,000
22	44	2,000	4,000	12,000
23	44	2,000	4,000	12,000
24	44	2,000	4,000	12,000
25	44	2,000	4,000	12,000
26	56	2,000	2,000	6,000

PINS	W	Q' ty/Reel	Q' ty/Inner Box	Q' ty/Box
27	56	2,000	2,000	6,000
28	56	2,000	2,000	6,000
29	56	2,000	2,000	6,000
30	56	2,000	2,000	6,000
31	56	2,000	2,000	6,000
32	56	2,000	2,000	6,000
33	56	2,000	2,000	6,000
34	56	2,000	2,000	6,000
35	56	2,000	2,000	6,000
36	72	2,000	2,000	6,000
37	72	2,000	2,000	6,000
38	72	2,000	2,000	6,000
39	72	2,000	2,000	6,000
40	72	2,000	2,000	6,000
41	72	2,000	2,000	6,000
42	72	2,000	2,000	6,000
43	72	2,000	2,000	6,000
44	72	2,000	2,000	6,000
45	72	2,000	2,000	6,000
46	72	2,000	2,000	6,000
47	72	2,000	2,000	6,000
48	88	2,000	2,000	6,000
49	88	2,000	2,000	6,000
50	88	2,000	2,000	6,000

W/T CAP

PINS	Q' ty/Tube	Q' ty/Inner Box	Q' ty/Box
2	/	/	/
3	97	48,500	97,000
4	97	48,500	97,000

W/O CAP

PINS	Q' ty/Tube	Q' ty/Inner Box	Q' ty/Box
2	2K/Tray	/	9,600
3	137	68,500	137,000
4	105	52,500	105,000

A4	2025/12/12	Standardization Drawing	BAO	OPERATION	DRAW	DATE	SCALE	FIT	PART NO.
A3	2023/02/03	ADD Flatness	XSR	x.x ±0.40	BAO	2025/12/12	UNIT	mm	SEE TABLE
A2	2017/04/14	MODIFY CAP	XSR	x.xx ±0.25	CHECK	DATE	SIZE	A4	TITLE:
A0	2012/07/05	NEW	-----	x.xxx ±0.15	TANG	2025/12/12	SHEET	3/3	1.27mm SINGLE FEMALE HEADER SMT H=2.10
REV	DATE	MODIFICATION DESCRIPTION	CHANGE	Angle ± 3'	APPROVE	DATE	PROJ.	Customer NO.	
				DIM TOL	Steven Zhao	2025/12/12			



Http: www.wcon.com

WCON-Dongguan Tel: +86 769 85358920 Fax: +86 769 85358915 E-mail: sales@wcon.com	WCON-Kunshan Tel: +86 512 57468408 Fax: +86 512 57468468 E-mail: salesks@wcon.com
---	--