

# HSHF

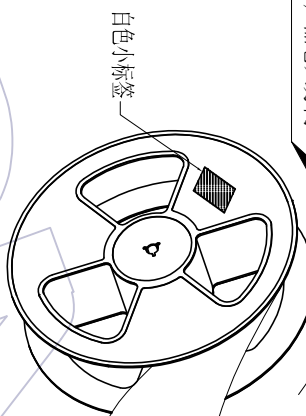
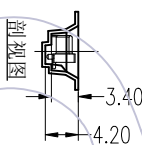
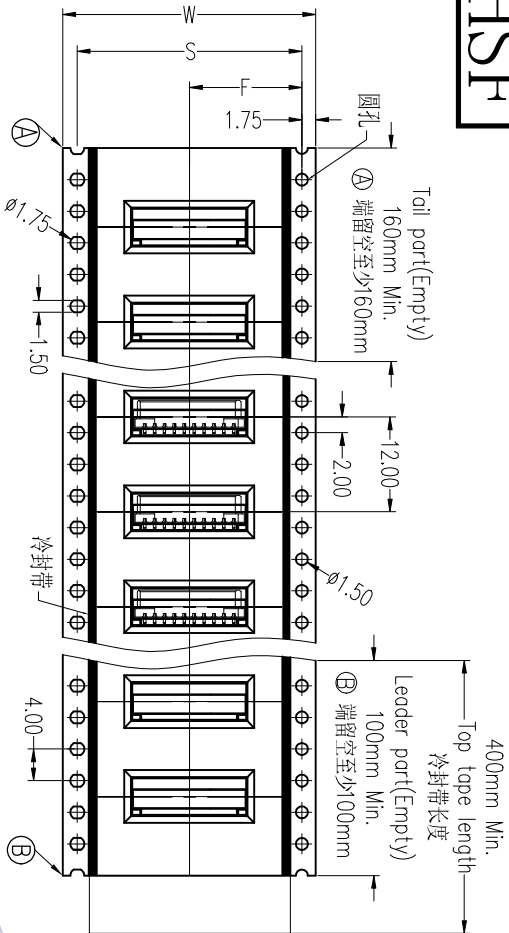

包装时产品卷入方向

客户安装时拉出方向  
Customer pull out direction

**No.1:**  
产品包装前,注意载带要留空160mm以上  
将产品放入载带凹槽后,用盖带封装,  
注意:盖带与承载带的拉力30g-120g

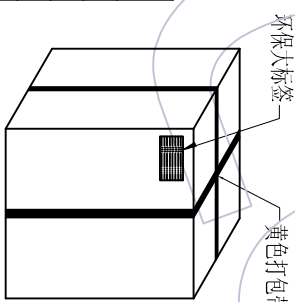

外箱: CTN-18K

**No.4:**  
封箱, 打包, 贴标签。

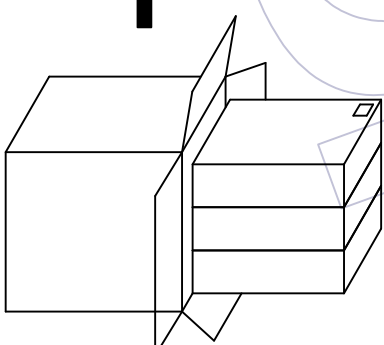

**No.3:**  
将内箱装入外箱(3内箱/外箱)  
注意统一标签方向

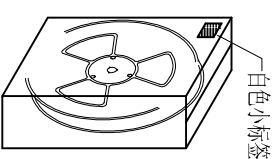

内箱: CTN-18E

**No.2:**  
将卷盘套上PE-32防水袋,  
放入1包干燥剂,  
真空机封口后装入内箱,  
用封箱胶封装好,并贴上标签。

PIN	载带料号	W	S	F	PCS/Reel	PCS/内箱	PCS/外箱
4P	TR3652-FN0004Z03601	16.0±0.30	/	7.50±0.15	1300	5200	15600
5P	TR3652-FN0005Z03601	16.0±0.30	/	7.50±0.15	1300	5200	15600
6P	TR3652-FN0006Z03601	24.0±0.30	/	11.50±0.15	1300	3900	11700
7P	TR3652-FN0007Z03601	32.0±0.30	28.40±0.10	14.20±0.15	1300	2600	7800
8P	TR3652-FN0008Z03601	32.0±0.30	28.40±0.10	14.20±0.15	1300	2600	7800
10P	TR3652-FN010203601	32.0±0.30	28.40±0.10	14.20±0.15	1300	2600	7800
17P	TR3652-17N4401	44.0±0.30	40.40±0.10	20.20±0.15	1300	2600	7800
20P	TR3652-FN020203601	44.0±0.30	40.40±0.10	20.20±0.15	1300	2600	7800

变更记事	版本	日期	变更说明	变更	核准
REV	DATE		MODIFICATION DESCRIPTION	CHANGE	APPROVE
A0	2020/11/11		NEW		

工程图		绘图		SCALE	
ENGINEERING	DRAW	DESIGN	CHECK	FIT	UNIT
XX	XX	设计	审核	mm	mm
XX	XX	DESIGN	CHECK	A4	A4
Angle	± 2	核准	核准	1/1	1/1
DIM	TOL	APPROVE	APPROVE	PROJ.	

WCON ELECTRONICS (GUANGDONG) CO., LTD	
料号	品名
PART NO.	TITLE:
3652-SXXX-034SRR01/2	1.25mm Board to Board R/A SMT Female, T TYPE W/T Post, H=3.40 卷装规范

1 2 3 4 5 6 7 8 9 10

1 2 3 4 5 6 7 8 9 10